



# RUGER®



black | 2.5778 - 4"  
chrome | 2.5779 - 4"



black | 2.5780 - 6"  
chrome | 2.5781 - 6"



black | 2.5680 - 8"  
chrome | 2.5681 - 8"

 **RUGER® SuperHawk**  
CO<sub>2</sub> AIRSOFT / cal. 6 mm BB

**EN** Operating instructions 2 - 8 | **DE** Bedienungsanleitung 9 - 15 | **FR** Mode d'emploi 16 - 22 | **ES** Manual de instrucciones 23 - 29

Manufactured Under License From Sturm, Ruger & Co., Inc.

12R13 © 2013



### DESCRIPTION



### OPERATION



### MAINTENANCE



### SAFETY INSTRUCTIONS

You should be fully familiar with the proper and safe handling of your gun. The basic principles of gun safety require you to always apply the following rules when handling the firearm.

- Always treat a gun as if it was loaded.
- Always put the safety of a gun to "safe" when loading it so that there can be no unintentional discharge.
- Keep your finger away from the trigger. It should be straight and should rest on the trigger guard.
- Only use the kind of projectiles suitable for your gun.
- Always keep the muzzle pointed in a safe direction.
- This gun may only be discharged in your own house, on authorized shooting ranges and inside enclosed private property. It is to be made sure that no projectile can leave the enclosed property.
- Keep the danger area of the projectile in mind.
- Never transport a loaded gun. Only load your gun when you intend to fire it.
- Never aim your airgun at persons or animals. Avoid ricochets. Never fire at smooth, hard surfaces or water.
- Before you discharge your gun, make sure that target and surrounding area are safe.
- Make sure that you always have full control over the muzzle of your gun, even if you stumble or fall down.
- Safety shooting glasses should always be worn when firing the gun.
- Always store your gun in a safe place and in unloaded condition. Unauthorized persons (persons not familiar with the use of gun, children) must not have access to it. Ammunition is to be kept in a separate place.
- This gun and its instruction manual may only be passed on to persons
  - who are fully familiar with its use and
  - who have reached the legally stipulated minimum age in the respective country.
- Modifications or repairs of gun are only to be effected by authorized agencies or by a skilled gunsmith.
- Never leave a loaded gun unattended.
- Only unloaded gun are to be handed over to another person.

### REPAIR

A gun that does not work properly is dangerous. Repairing a gun by oneself is difficult and an incorrectly assembled gun can malfunction in dangerous ways.

**Caution: Repairs should only be completed by UMAREX authorized centres.**



## SAFETY INSTRUCTIONS | WARRANTY



## DESCRIPTION

EN



### CAUTION

For your own safety and the safety of others, carefully read these instructions before using this gun. Buyers and owners must observe all rules concerning the use and ownership of air guns. Modifying this gun may result in a change of its classification under gun law and is therefore prohibited. In such cases the manufacturer's warranty will immediately become void.



### WARNING

Do not brandish or display this airgun in public - it may confuse people and may be a crime. Police and others may think this airgun is a firearm. Do not change the coloration and markings to make it look more like a firearm. That is dangerous and may be a crime.

### WARRANTY

During the legal warranty period, which begins on the date of purchase, UMAREX will repair or replace your gun at no charge provided the defect was not caused by you. Return your gun to an authorized dealer along with a description of the problem and proof of purchase.

The air guns manufactured by UMAREX Sportwaffen GmbH & Co. KG are made according to the regulations of the PTB (Physikalisch-Technische Bundesanstalt), German federal law, the CIP regulations and the technical know-how of UMAREX Sportwaffen GmbH & Co. KG.

We will not assume any liability whatsoever if this product is exported to territories outside of Germany and as a consequence does not comply with domestic legal requirements of these territories. It will be the sole responsibility of the importer to ensure compliance with local laws and regulations.

### TECHNICAL DATA

Item No.	2.5780	2.5781	2.5680	2.5681	2.5778	2.5779
System	CO <sub>2</sub> Airsoft					
Caliber/Ammo	cal. 6 mm BB					
Energy	< 3,0 JOULES		< 4,0 JOULES		< 2,0 JOULES	
Velocity	up to 145 m/s with 0,25 g BB		up to 175 m/s with 0,25 g BB		up to 125 m/s with 0,25 g BB	
Barrel length	160 mm		202 mm		100 mm	
Length	295 mm		345 mm		250 mm	
Weight	930 g		990 g		945 g	
Colour	black	chrome	black	chrome	black	chrome
Magazine capacity	8 BBs				6 BBs	
Dangerous area up to	200 m					



 CAUTION

- Only handle the gun when it is in its safe condition.
- Always make sure that the muzzle points into a safe direction.

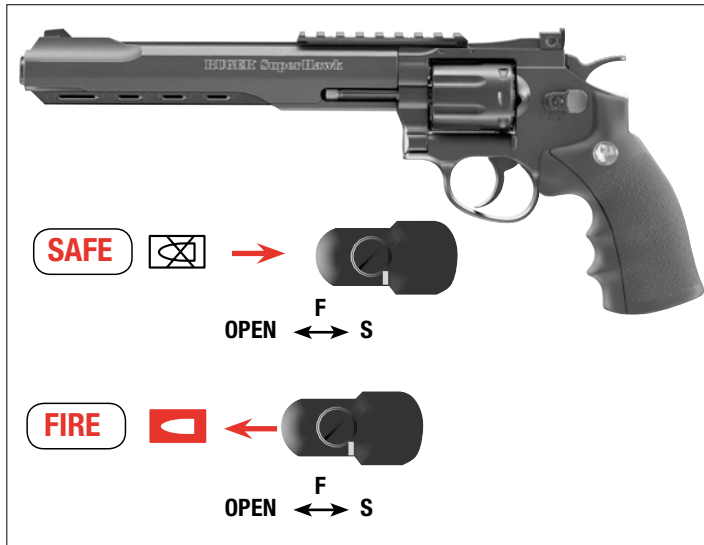
 CAUTION

- Only use 12 g CO<sub>2</sub> capsules. • For storage remove gas capsules.
- There may be a minor discharge of gas when you remove the gas capsules. Make sure that your hands do not come into contact with discharged CO<sub>2</sub> gas. This may cause freezing of the skin. Do not expose the CO<sub>2</sub> cartridge to excessive heat and do not store it at temperatures exceeding 54°C. Always adhere to the warnings and safety instructions of the manufacturer on the gas cartridge in respect to handling and storage of a CO<sub>2</sub> gas container.

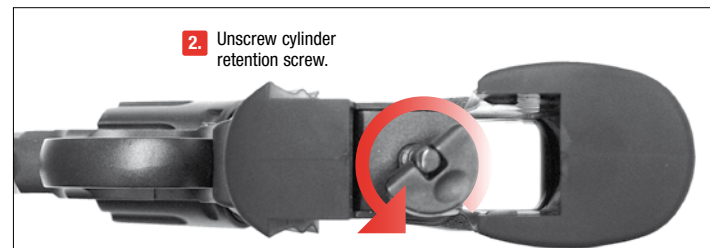



## INSERTING AND CHANGING CO<sub>2</sub> CAPSULE

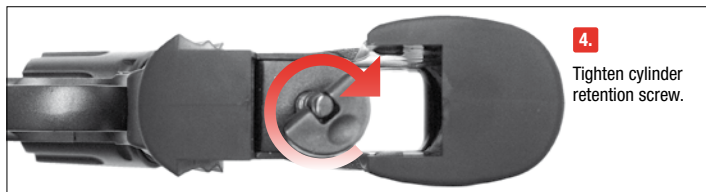

## LOADING THE MAGAZINE

EN

### ⚠ CAUTION



**Only use flawless BBS. Never use the following BBS:**

**1** diameter larger than 6mm, **2** with edges, **3** both halves not aligned, **4** used, soiled. Warranty expires if non-recommended BBs are used.

It's recommended to use precision BBs from UMAREX/Walther.

To ensure proper operation of the magazine, protect it from dirt and dust.



2.5680 / 2.5681 / 2.5780 / 2.5781

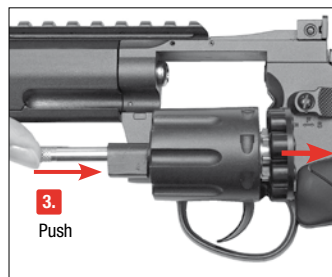

2.5778 / 2.5779

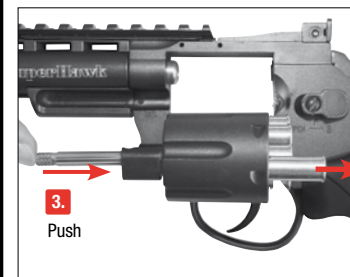



## LOADING THE MAGAZINE

EN

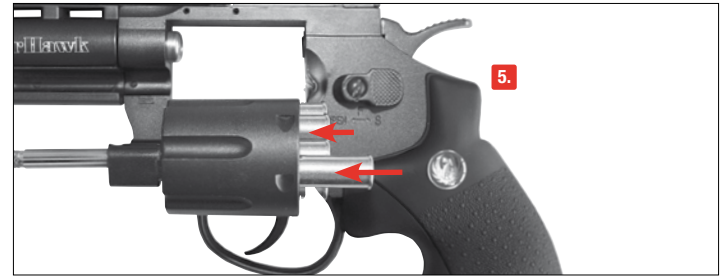
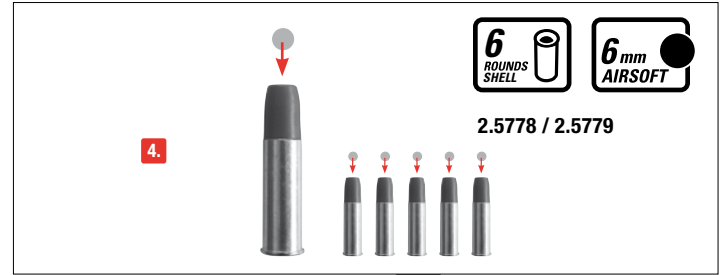
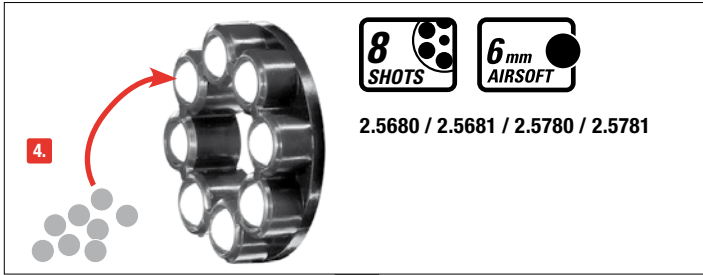

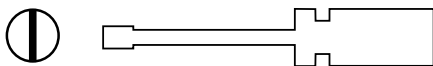

**Elevation adjustment**

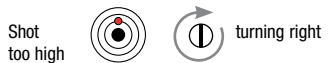

**Windage adjustment**

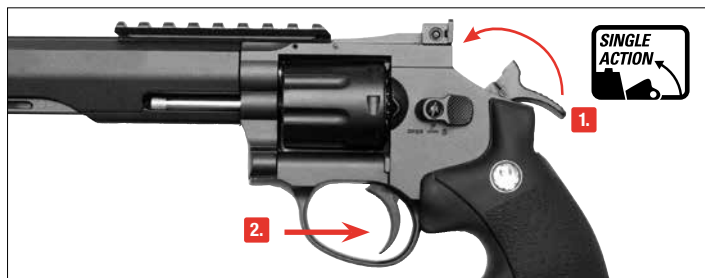
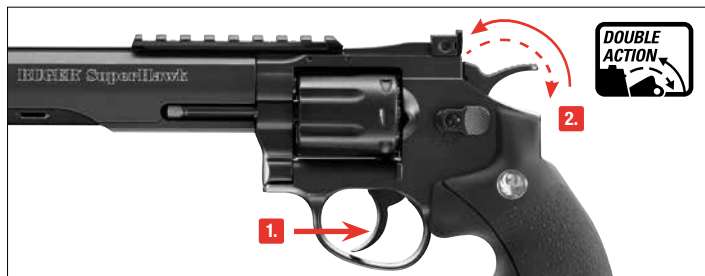
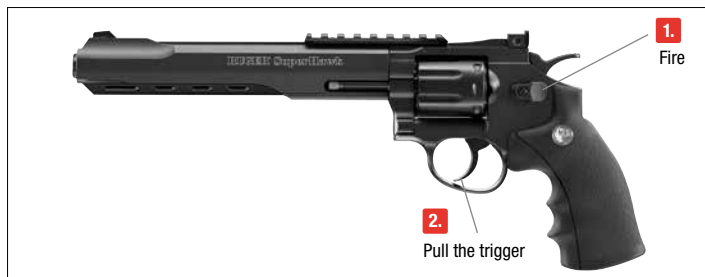
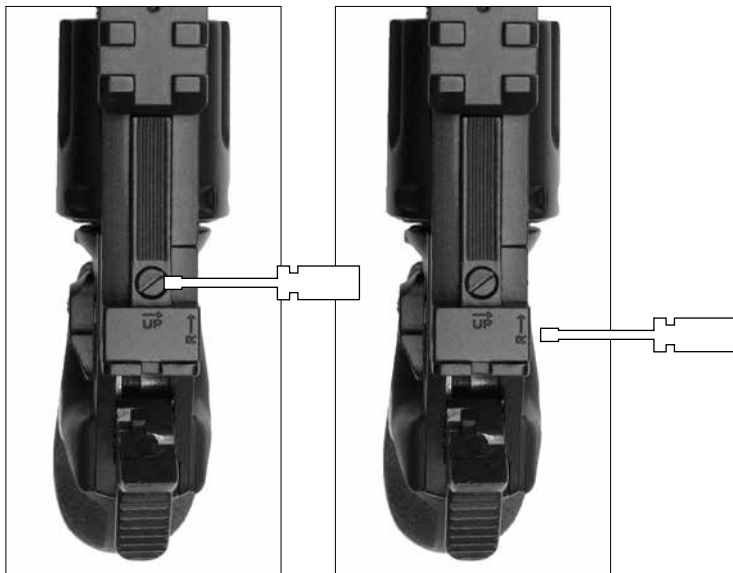



## DEMOUNTING

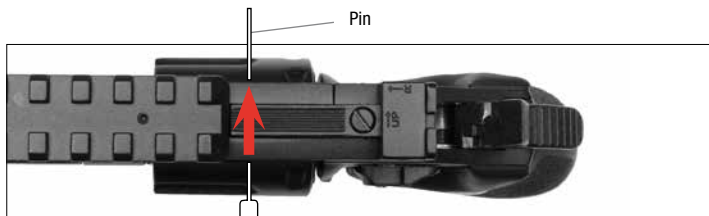

1. Knock out the pin
2. Switch off the elevation screw
3. Remove sight
4. Push back the picatinny rail

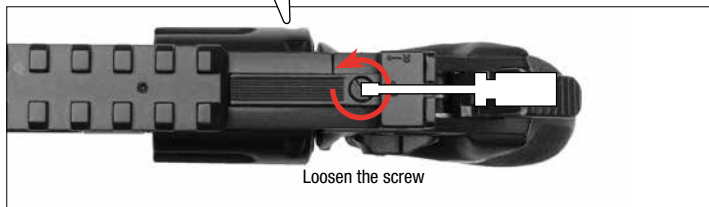

Loosen the screw

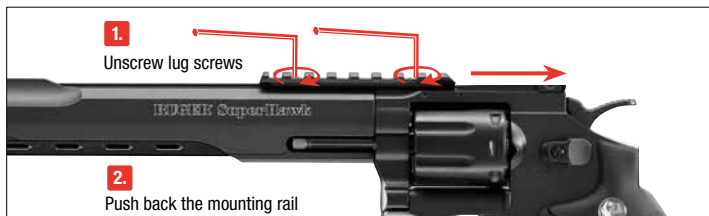

1. Unscrew lug screws

2. Push back the mounting rail



## BARREL CLEANING

EN



### CAUTION

- Adjust the shoot up in normal position, before cleaning the gun.
- Do not force the rod into the barrel, as this could cause damage.
- Never drip silicone oil directly into the barrel.

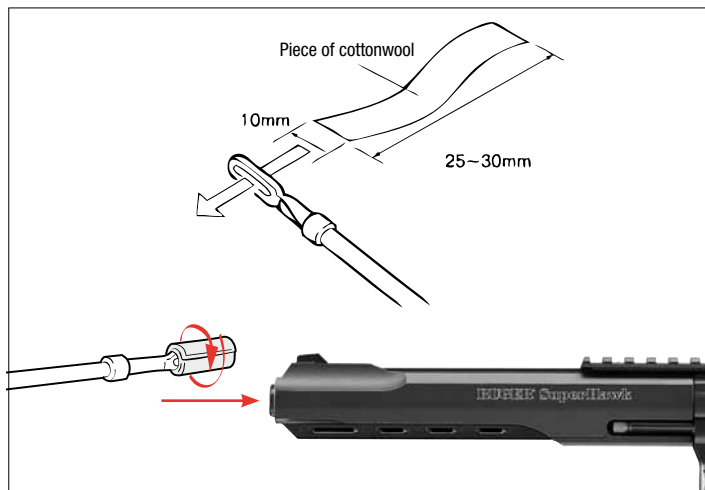

Put the safety on „safe“ and remove the magazine. Prepare a thin rod with a length of approx. 40 cm. Attach a piece of cotton fabric to its end and clean the barrel with some silicone oil.





### BENENNUNG



### BEDIENUNG





### PFLEGE



### SICHERHEITSHINWEISE

Sie sollten mit der richtigen, sicheren Handhabung Ihrer Waffe vertraut sein. Im Hinblick auf die Grundregeln zum sicheren Schießen bedenken Sie, dass jede Berührung mit der Waffe als Handhabung verstanden wird.

- Behandeln Sie jede Waffe so, als wäre sie geladen.
- Die Waffe beim Laden stets sichern, so dass sich kein Schuss ungewollt lösen kann. Finger immer außerhalb des Abzugbügels halten und nur zum Schuss an den Abzug legen.
- Verwenden Sie nur für diese Waffe vorgesehene Geschosse.
- Halten Sie die Mündung stets in eine sichere Richtung.
- Das Schießen ist nur in der eigenen Wohnung, auf polizeilich zugelassenen Schießständen und im befriedeten Besitztum erlaubt, wenn das Geschoss dieses beim Schuss nicht verlassen kann. Hierbei den Gefahrenbereich des Geschosses beachten.
- Transportieren Sie niemals eine geladene Waffe. Laden Sie nur, wenn Sie schießen möchten.
- Waffe niemals auf Menschen oder Tiere richten. Vermeiden Sie Querschläger. Schießen Sie niemals auf glatte, harte Oberflächen oder auf Wasserflächen.
- Vergewissern Sie sich vor dem Schuss, dass Ziel und Umgebungsbereich sicher sind.
- Kontrollieren Sie immer, ob die Waffe ungeladen ist, wenn Sie sie transportieren oder von einer anderen Person übernehmen.
- Vergewissern Sie sich, dass Sie. auch beim Stolpern oder Stürzen die Richtung der Mündung kontrollieren können.
- Aus Sicherheitsgründen sollte beim Schießen eine Schutzbrille getragen werden.
- Aufbewahren der Waffe stets sicher und ungeladen vor unerlaubtem Zugriff Unbefugter (ungeschulte Personen, Kinder, Personen unter 18 Jahren) und getrennt von der Munition.
- Weitergabe dieser Waffe mit der Bedienungsanleitung nur an Personen
  - die mit der Handhabung dieser Waffe genauestens vertraut und bei Waffen mit -Zeichen mindestens 18 Jahre alt sind.
- Druckluftwaffen mit Energie > 0,5 Joule aber ohne -Zeichen sind erwerbscheinpflichtig.
- Jegliche Veränderungen oder Reparaturen von Waffen sollten nur von fachkundigen Firmen oder vom Büchsenmacher durchgeführt werden.
- Legen Sie niemals eine geladene Waffe aus der Hand.
- Geben Sie nur entladene Waffen an andere Personen weiter.

### REPARATUR

Eine Waffe, die nicht einwandfrei funktioniert, ist gefährlich. Es ist schwierig, eine Waffe selbst zu reparieren, und falscher Zusammenbau kann zu gefährlichen Funktionsstörungen führen.

**Achtung: Lassen Sie die Waffe nur von einem autorisiertem Fachhändler/ Büchsenmacher überprüfen und reparieren.**



**ACHTUNG**

Zu Ihrer eigenen und zur Sicherheit anderer lesen Sie die Bedienungsanleitung vollständig und sorgfältig durch, bevor Sie mit der Waffe erstmalig hantieren. Käufer und Besitzer haben die Pflicht, alle Regeln über den Gebrauch und den Besitz von Druckluftwaffen zu befolgen. Jede Änderung an dieser Waffe kann zu einer Änderung der waffenrechtlichen Einstufung führen und ist somit unzulässig. Die Gewährleistung des Herstellers erlischt in diesem Fall sofort.

**WARNUNG**

Diese Druckluftwaffe nicht in der Öffentlichkeit zeigen oder mit ihr drohen – es führt zu Verwechslungen mit echten Waffen und gilt als Straftat. Ändern Sie keinesfalls die Farbe und Markierungen der Druckluftwaffe, um ihr Aussehen mehr einer realen Schusswaffe anzugleichen. Dies ist gefährlich und gilt als Straftat.

**GARANTIE**

Innerhalb des gesetzlich festgelegten Zeitraumes ab Kaufdatum repariert oder ersetzt Ihnen die Fa. UMAREX Ihre Waffe kostenlos, falls der Defekt nicht durch Eigenverschulden aufgetreten ist. Geben Sie die Waffe einem autorisierten Händler, beschreiben Sie ihm das Problem und fügen Sie den entsprechenden Kaufbeleg bei.

Die von UMAREX Sportwaffen GmbH & Co. KG hergestellten Druckluftwaffen werden gemäß den Zulassungsvorschriften der Physikalisch-Technischer Bundesanstalt (PTB), dem Bundesgesetz, den CIP-Vorschriften und dem waffentechnischen Know-how der Firma UMAREX Sportwaffen GmbH & Co. KG hergestellt.

Somit übernehmen wir keine Haftung, falls diese Ware nach dem Export ins Ausland nicht den dort geltenden Rechtsvorschriften entsprechen sollte und dem Besitzer/Käufer juristische Schwierigkeiten und Konsequenzen daraus entstehen sollten.

**TECHNISCHE DATEN**

Art. Nr.	2.5780	2.5781	2.5680	2.5681	2.5778	2.5779
System	CO <sub>2</sub> Airsoft					
Kaliber/Munition	cal. 6 mm BB					
Energie	< 3,0 JOULES $\hat{=}$		< 4,0 JOULES $\hat{=}$		< 2,0 JOULES $\hat{=}$	
Geschwindigkeit	bis zu 145 m/s mit 0,25 g BB		bis zu 175 m/s mit 0,25 g BB		bis zu 125 m/s mit 0,25 g BB	
Lauflänge	160 mm		202 mm		100 mm	
Gesamtlänge	295 mm		345 mm		250 mm	
Gewicht	930 g		990 g		945 g	
Farbe	schwarz	chrom	schwarz	chrom	schwarz	chrom
Magazinkapazität	8 BBs				6 BBs	
Gefahrenbereich max.	200 m					





**⚠️ ACHTUNG**

- Hantieren Sie nur mit der Waffe, wenn diese gesichert ist.
- Achten Sie stets darauf, dass die Mündung in eine sichere Richtung zeigt.

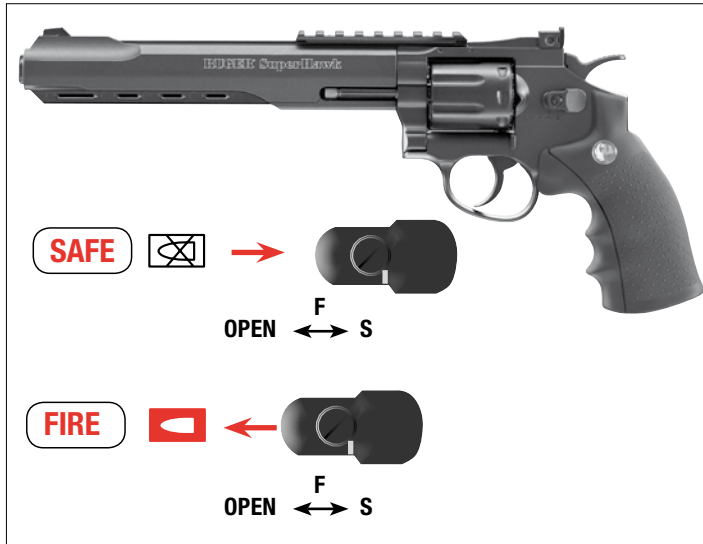

**⚠️ ACHTUNG**

- Verwenden Sie nur 12 g CO<sub>2</sub>-Kapseln. • Für die Lagerung der Waffe CO<sub>2</sub>-Kapsel entnehmen!
- Beim Herausnehmen der CO<sub>2</sub>-Kapsel kann es zu einem leichten Austritt von CO<sub>2</sub> kommen. Achten Sie darauf, dass Ihre Hände nicht mit austretendem CO<sub>2</sub> Gas in Berührung kommen. Bei Kontakt mit der Hand kann es zu Erfrierungen kommen. Setzen Sie die CO<sub>2</sub> Kapsel keiner großen Hitze aus und lagern Sie diese Behälter nicht bei Temperaturen über 54°C. Halten Sie sich immer an die auf der CO<sub>2</sub> Kapsel ausgedruckten Warn- und Sicherheitshinweise des Herstellers bezüglich Umgang und Lagerung der CO<sub>2</sub> Kapsel.

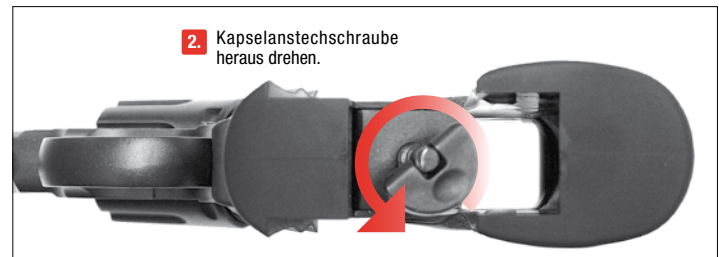

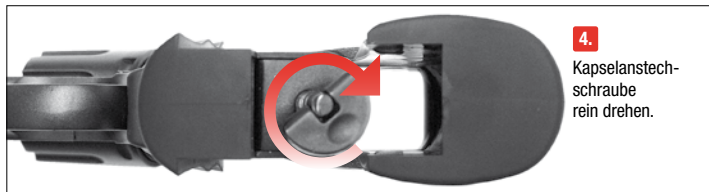

## ⚠ ACHTUNG

**Verwenden Sie nur einwandfreie BB-Kugeln: ø 6 mm.**  
**Verwenden Sie auf keinen Fall folgende BB-Kugeln:**  
**1** Durchmesser größer als 6 mm, **2** mit Grat, **3** versetzte Hälften, **4** gebraucht, verschmutzt.  
 Bei Gebrauch ungeeigneter Geschosse erlischt die Garantie. Empfohlen werden Präzisionsrundkugeln des Herstellers Umarex/Walther. Vermeiden Sie das Eindringen von Schmutz und Staub in das Magazin.



2.5680 / 2.5681 / 2.5780 / 2.5781

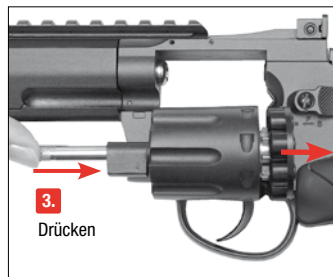

2.5778 / 2.5779

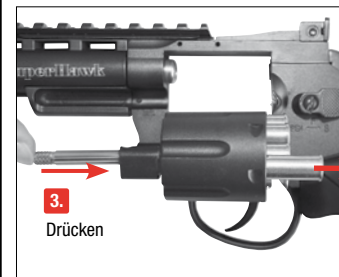



# MAGAZIN LADEN

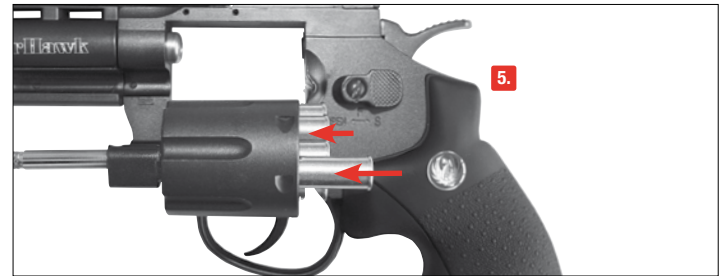
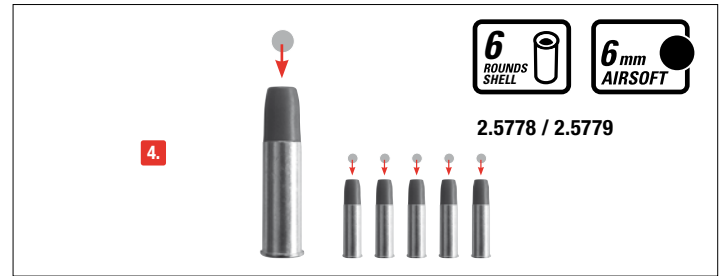
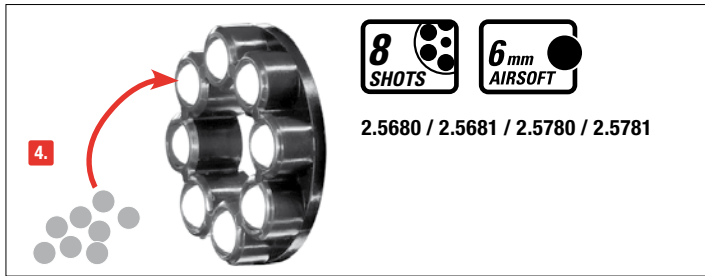



## VISIERUNG

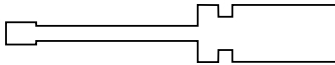

### Höhenverstellbar

Schuss zu hoch



nach rechts drehen

Schuss zu tief



nach links drehen (in Richtung „UP“)

### Windage adjustment

Schuss zu weit links



nach rechts drehen

Schuss zu weit rechts



nach links drehen

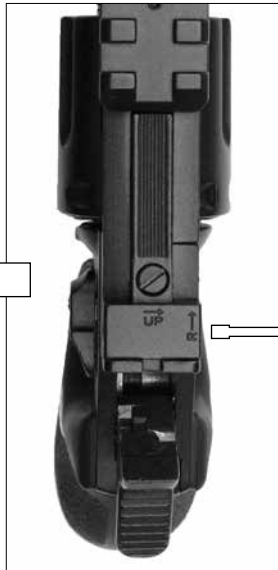
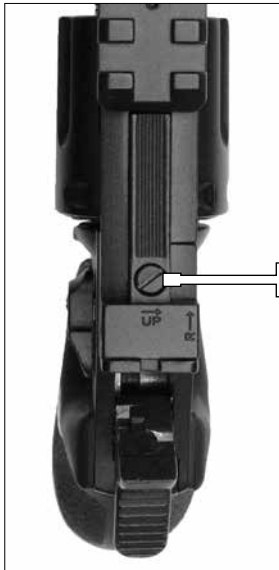

## SCHIESSEN

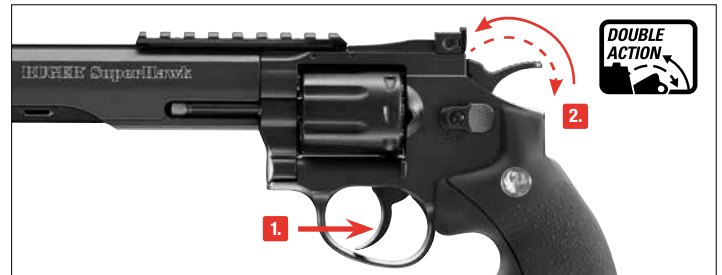

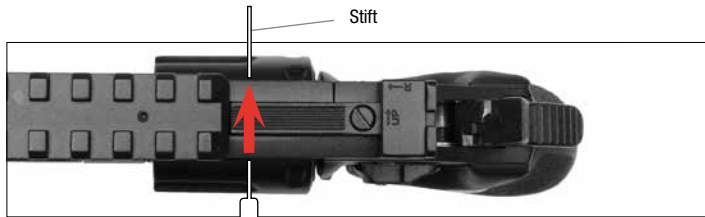

1. Stift herauschagen

2. Höhenschraube  
abdrehen

3. Visier abnehmen

4. Picatinny-Rail nach  
hinten abschieben

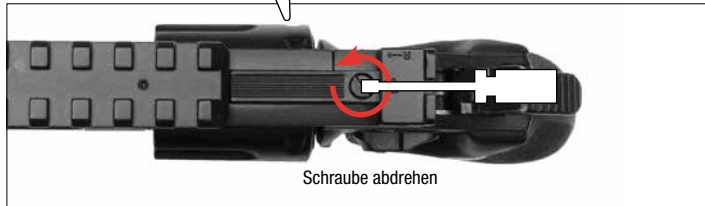

**⚠ ACHTUNG**

- Schieben Sie den Stab niemals mit Gewalt in den Lauf, dies kann Beschädigungen verursachen.
- Reinigen Sie gelegentlich die äußeren Metallteile. Benutzen Sie dazu ein Tuch, auf das Sie leicht Waffenöl aufgetragen haben.
- Geben Sie niemals das Waffenöl direkt in den Lauf.

**1. SAFE**

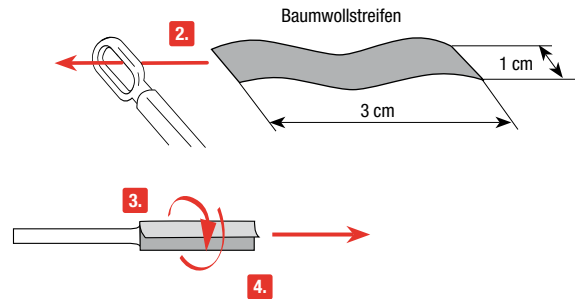

Sichern Sie die Waffe. Nehmen Sie einen ca. 30 cm dünnen, langen Stab. Wickeln Sie ein Stück Baumwolltuch um das Ende, benetzen Sie das Tuch mit etwas Waffen-Öl und reinigen Sie damit den Lauf.



## DESIGNATION



## UTILISATION



## ENTRETIEN



## INSTRUCTIONS DE SÉCURITÉ

Vous devez savoir manier votre arme correctement et de manière sûre et devez impérativement respecter les règles de base de tir en toute sécurité à chaque fois que vous manipulez l'arme.

- Maniez toujours l'arme comme si elle était chargée.
- Mettez toujours la sûreté avant de charger l'arme afin d'éviter tout tir involontaire.
- Ne mettez pas le doigt sur la détente et ne l'y placez que lorsque vous allez tirer.
- N'utilisez que les projectiles prévus pour cette arme.
- Pointez toujours la bouche de l'arme dans une direction non dangereuse.
- Il n'est permis de tirer avec l'arme que sur le lieu de résidence du propriétaire ou dans des zones de tir autorisées par la police, à condition que le projectile ne puisse pas sortir de la zone de tir. Veuillez toujours prendre en compte la zone de danger maximale du projectile.
- Ne transportez jamais l'arme lorsqu'elle est chargée. Ne la chargez que lorsque vous vous apprêtez à tirer.
- Ne dirigez jamais l'arme vers des personnes ni des animaux. Évitez les tirs pouvant faire ricocher le projectile. Ne tirez jamais sur des surfaces planes et dures, ni sur une surface d'eau car les projectiles peuvent ricocher.
- Avant de tirer, assurez-vous que l'objectif et les alentours ne présentent pas de danger.
- Vérifiez toujours que l'arme est déchargée avant de la transporter ou de la remettre à autrui.
- Veillez à maîtriser la direction dans laquelle la bouche de l'arme est pointée, même si vous trébuchez ou tombez.
- Pour des raisons de sécurité, portez des lunettes de protection lorsque vous tirez.
- Rangez toujours l'arme déchargée, séparée des munitions et dans un endroit sûr afin d'éviter que des personnes non autorisées (personnes non formées, enfants) puissent y avoir accès.
- Ne remettez cette arme, accompagnée du mode d'emploi, qu'à des personnes
  - qui sont le plus possible formées au maniement de cette arme et
  - qui ont atteint l'âge minimum légal selon la loi sur les armes en vigueur dans votre pays.
- Toute modification ou réparation de l'arme devra être effectuée par une entreprise spécialisée ou un armurier.
- Ne laissez jamais l'arme chargée sans surveillance.
- Déchargez toujours l'arme avant de la remettre à autrui.

## RÉPARATIONS

Une arme qui ne fonctionne pas parfaitement est dangereuse. Il est difficile de réparer une arme soi-même, et un remontage incorrect peut entraîner des dysfonctionnements dangereux.

**Attention : seules des personnes spécialisées agréées ou un armurier peuvent contrôler et réparer l'arme.**

Cette boîte contient: une réplique d'arme factice avec chargeur. Les AIRSOFT GUNS sont des modèles d'armes factices tirant des billes en plastique de 6 mm inoffensives. Ce modèle a une énergie comprise entre 0,08 joule et inférieure ou égale à 2 joules. En France, la vente de ces produits est réglementée par le décret n°99-240 du 24 mars 1999, qui interdit la distribution des modèles noirs ou chromés dont l'énergie est comprise entre 0,08 et 2 joules aux moins de 18 ans non accompagnés. Ce décret ne concerne pas les modèles transparents, les game guns (oranges) et les mini guns, dont la distribution reste donc autorisée aux mineurs.

- Distribution et vente interdite aux mineurs. • Attention: Ne jamais diriger le tir vers une personne.





**ATTENTION**

Pour votre sécurité et celle d'autrui, lisez attentivement la notice d'emploi avant d'utiliser l'arme pour la première fois. Les vendeurs, tout comme les acheteurs, ont l'obligation de respecter le règlement relatif à l'utilisation et à la possession d'armes à air comprimé. Il est interdit de procéder à toute modification de ce pistolet car cela pourrait entraîner un changement dans la classification correspondant à la législation sur les armes à feu. De plus, toute modification entraînerait l'annulation immédiate de la garantie du fabricant.



**MISE EN GARDE**

Mise en garde: N'exhibez pas cette arme à air comprimé et ne la sortez pas en public. Cela pourrait prêter à confusion ou être considéré comme un délit. Les membres des forces de sécurité et la police pourraient la prendre pour une vraie arme à feu. Ne changez pas sa couleur ni les éléments d'identification pour qu'elle ressemble plus à une vraie arme à feu. Cela serait dangereux et peut être considéré comme un délit.

**GARANTIE**

La société UMAREX s'engage à réparer ou à remplacer votre arme durant une période déterminée légalement à compter de la date d'achat, à condition que vous ne soyez pas responsable du défaut. Pour cela, remettez l'arme à un revendeur autorisé, décrivez-lui le problème et joignez le justificatif d'achat correspondant.

Les armes à air comprimé de la société UMAREX Sportwaffen GmbH & Co. KG sont fabriquées conformément aux directives de conformité de l'institut allemand « Physikalisch-Technische Bundesanstalt (PTB) », à la loi fédérale, aux prescriptions CIP et au savoir-faire technique de la société UMAREX Sportwaffen GmbH & Co. KG dans le domaine des armes.

Ainsi, nous ne pouvons être tenus responsables si, après exportation à l'étranger, cette marchandise ne répond pas aux prescriptions légales en vigueur dans le pays en question et si le possesseur/acheteur doit pour cette raison faire face à des difficultés juridiques ou toute autre conséquence pouvant découler de ce fait.

**FICHE TECHNIQUE**

Numéro d'article	2.5780	2.5781	2.5680	2.5681	2.5778	2.5779
Système	CO <sub>2</sub> Airsoft					
Calibre/Munitions	cal. 6 mm BB					
Energie	< 3,0 JOULES		< 4,0 JOULES		< 2,0 JOULES	
Vitesse	jusque 145 m/s avec 0,25 g BB		jusque 175 m/s avec 0,25 g BB		jusque 125 m/s avec 0,25 g BB	
Longueur canon	160 mm		202 mm		100 mm	
Longueur	295 mm		345 mm		250 mm	
Poids	930 g		990 g		945 g	
Couleur	noir	chrome	noir	chrome	noir	chrome
Capacité	8 BBs				6 BBs	
Zone de danger s'étendant jusqu'à	200 m					

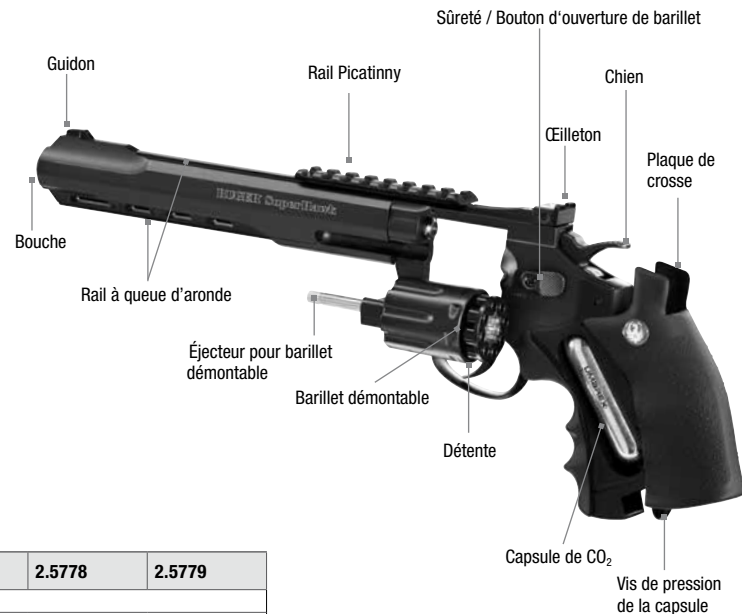

 **ATTENTION**

- Ne manipulez l'arme lorsque la sécurité est enclenchée.
- Assurez-vous que la bouche est orientée dans une direction non dangereuse.

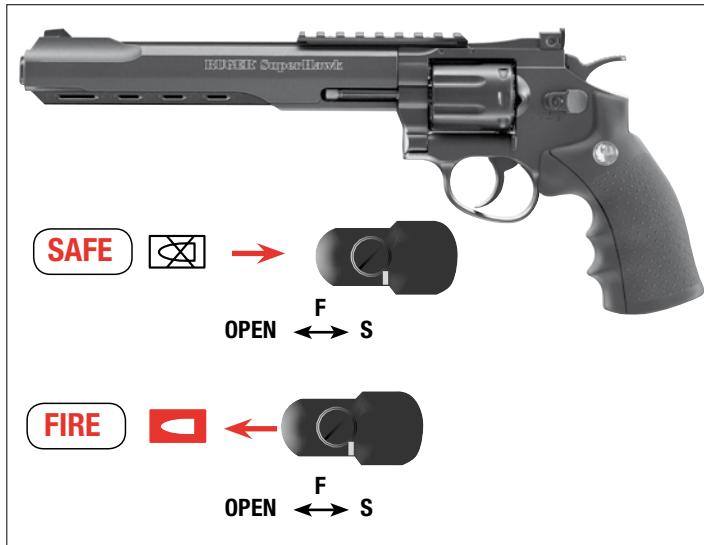
 **ATTENTION**

- Utilisez seulement des cartouches de CO<sub>2</sub> de 12 g.
- Retirez la cartouche de CO<sub>2</sub> avant de ranger l'arme.
- En retirant la cartouche de CO<sub>2</sub>, il est possible qu'une petite quantité de gaz s'échappe. Veillez à ce que vos mains n'entrent pas en contact avec le gaz CO<sub>2</sub> qui s'échappe. Le contact avec la peau peut entraîner des gelures. Ne soumettez pas les cartouches de CO<sub>2</sub> à une chaleur trop importante et ne les stockez pas à des températures supérieures à 54 °C. Respectez toujours les consignes de sécurité et avertissements figurant sur la cartouches de CO<sub>2</sub> relatifs à l'utilisation et au stockage de capsules de CO<sub>2</sub>.

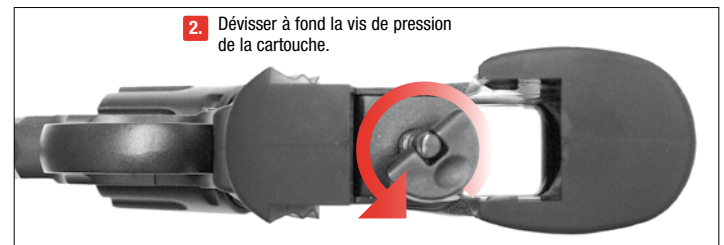



## INSERTION, CHANGEMENT ET RETRAIT DE LA CARTOUCHE DE CO<sub>2</sub>

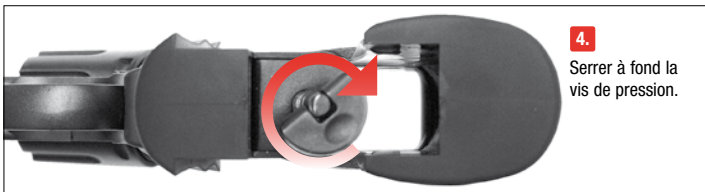

## CHARGEMENT DES BILLES BB

FR

### ⚠ ATTENTION



N'utilisez que des billes BB (sans défaut). N'utilisez jamais les types de billes BB suivants: **1** Avec angles **2** Moitiés déplacées **3** Usagées ou sales. Si des projectiles autres que ceux appropriés sont utilisés, la garantie ne sera plus valable. Il est recommandé d'utiliser des billes de précision de la marque UMAREX/Walther. Pour garantir le bon fonctionnement du chargeur, faites en sorte que les saletés et poussières n'entrent pas dans le chargeur.



2.5680 / 2.5681 / 2.5780 / 2.5781

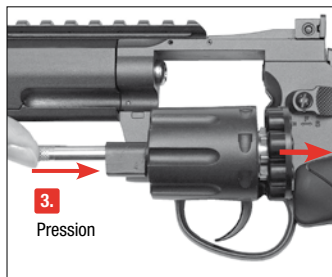

2.5778 / 2.5779



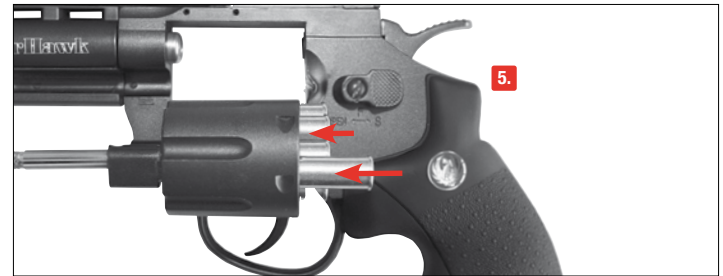
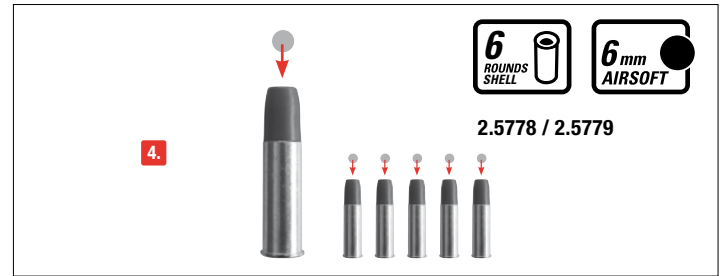
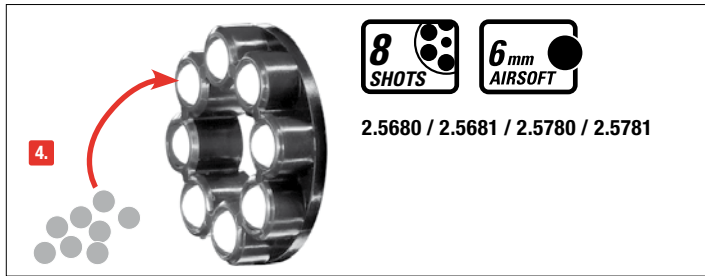

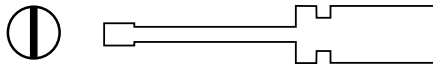

**Ajustage d'hauteur**

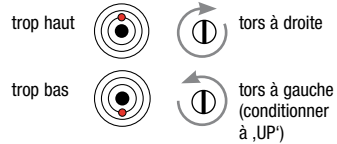

**Ajustage latéral**

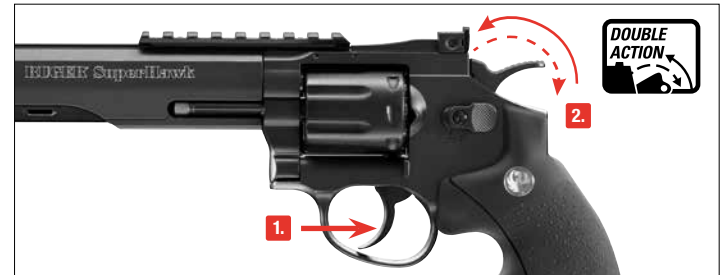
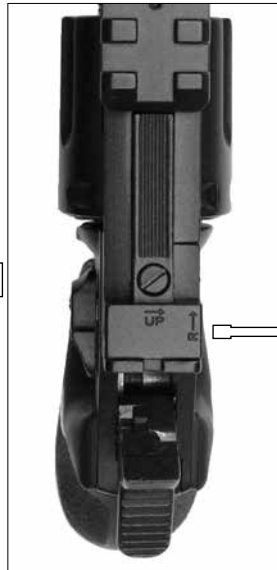
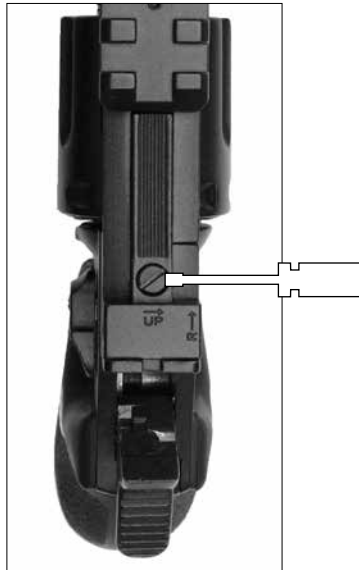
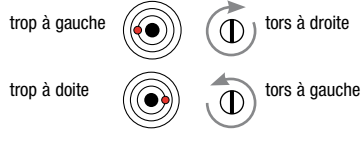



## DÉMONTAGE



## NETTOYAGE DU CANON

FR

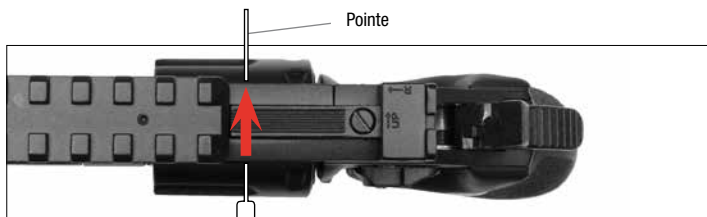

1. Extraire la pointe
2. Eteindre la vis pour ajuster l'hauteur
3. Retirer le viseur
4. Ecarter le rail Picatinny à l'arrière

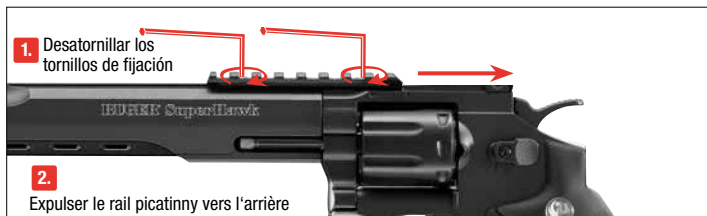
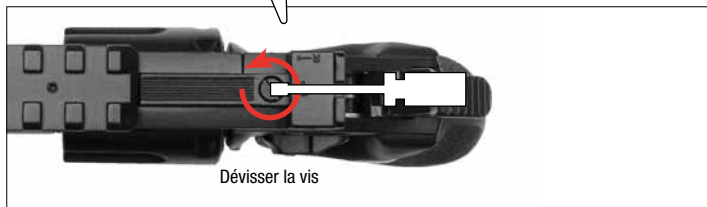

## ATTENTION

- Reajuster le „shoot up“ à „Normal“ avant de nettoyer l'arme.
- N'enfoncez pas la baguette de nettoyage violemment dans le canon, car elle pourrait l'endommager.
- Ne versez jamais l'huile de silicone directement dans le canon.

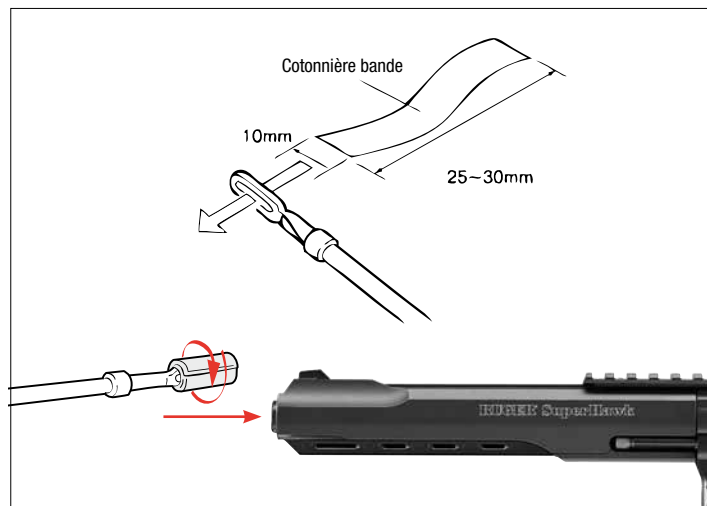

Mettez la sûreté de l'arme. Retirez le chargeur. Prenez un bâton mince d'une longueur d'env. 40 cm. Paillez un morceau d'un chiffon de coton autour du bout, mouillez le chiffon avec une petite quantité d'huile pour arme afin de nettoyer le canon.



### DESIGNACION



### REGLAJE



### CUIDADOS



### INSTRUCCIONES DE SEGURIDAD

Deberá estar familiarizado con el manejo correcto y seguro de su arma. Con respecto a las reglas básicas para disparar con seguridad, considere cada contacto con el arma como parte de su manejo.

- Trate el arma como si siempre estuviera cargada.
- Cargue siempre el arma con el seguro activado para evitar disparos involuntarios.
- Mantenga el dedo siempre fuera del gatillo y colóquelo solamente cuando vaya a disparar.
- Utilice únicamente proyectiles específicos para esta arma.
- Mantenga la boca del arma siempre en una dirección segura.
- Sólo está permitido disparar el arma en la vivienda del propietario o en las zonas de tiro autorizadas por la policía, siempre y cuando el proyectil no pueda llegar más allá del área de tiro. Para ello, tenga presente siempre la distancia máxima de peligro del proyectil.
- Nunca transporte el arma cargada. Cárguela solamente cuando tenga intención de disparar.
- Nunca apunte con el arma hacia personas o animales. Evite los disparos en los que el proyectil pueda rebotar: nunca dispare sobre superficies lisas y duras, ni al agua.
- Antes de disparar, asegúrese de que el objetivo y el entorno sean seguros.
- Antes de transportar el arma o de recibirla de manos de otra persona compruebe siempre que está descargada.
- Asegúrese de poder controlar la dirección hacia la que apunta la boca, aún en caso de tropiezo o de caída del arma.
- Por motivos de seguridad, cuando vaya a disparar póngase siempre gafas protectoras.
- Guarde el arma siempre descargada, separada de la munición y en lugar seguro para evitar que personas no aptas (personas sin formación, niños) puedan acceder a ella.
- Entregue esta arma, junto con las instrucciones de uso, únicamente a aquellas personas que:
  - estén perfectamente familiarizadas con el manejo de esta arma
  - hayan cumplido la edad mínima correspondiente fijada por la legislación en materia de armas del país respectivo.
- Cualquier modificación o reparación del arma deberá llevarla a cabo una empresa especializada o un armero.
- Nunca deje sin vigilancia un arma cargada.
- Siempre que entregue un arma a otra persona, asegúrese de que está descargada.

### REPARACIONES

Una arma que no funcione perfectamente es peligrosa. Es difícil reparar uno mismo un arma, y un ensamblaje incorrecto puede producir anomalías de funcionamiento peligrosas.

**Atención: La comprobación y reparación del arma sólo pueden llevarla a cabo especialistas autorizados o un armero.**



## ⚠️ ATENCIÓN

Por su propia seguridad y la de los demás, lea detenidamente las instrucciones de uso antes de disparar el arma por primera vez. Vendedores y compradores están obligados a cumplir con las normas de uso y posesión de armas de aire comprimido. Queda prohibida cualquier modificación de esta arma, ya que ello podría implicar un cambio en su clasificación legal. En caso de modificación quedaría extinguida de inmediato la garantía del fabricante.

## ⚠️ AVISO

No porte o muestre este arma de aire comprimido en público. Puede ser motivo de confusiones e ilegal. Miembros de las fuerzas de seguridad y la policía pueden tomarla por un arma de fuego real. No modifique el color ni los elementos identificativos para hacer que se parezca más a un arma de fuego real. Es peligroso y puede ser un delito

## GARANTIA

La empresa UMAREX se responsabiliza de reparar o sustituir su producto sin coste alguno en el plazo legalmente fijado a partir de la fecha de compra, siempre que el defecto no sea responsabilidad del propio usuario. Entregue el arma a un comerciante autorizado, descríbase el problema y adjunte el correspondiente comprobante de compra.

Las armas de aire comprimido de la empresa UMAREX Sportwaffen GmbH & Co. KG se fabrican de conformidad con las normas de homologación del Instituto Federal PTB (Physikalisch-Technischer Bundesanstalt), con la Ley Federal alemana, la normativa que establece el centro CIP y la experiencia en fabricación de armas de UMAREX Sportwaffen GmbH & Co. KG.

Por eso, no asumimos ninguna responsabilidad en el caso de que al exportar el arma a un país extranjero, ésta no cumpliera con la normativa legal local y el propietario o comprador tuviera que responder jurídicamente por dicho incumplimiento.

## ESPECIFICACIONES

Número de artículo	2.5780	2.5781	2.5680	2.5681	2.5778	2.5779
Sistema	CO <sub>2</sub> Airsoft					
Calibre / Munición	cal. 6 mm BB					
Energía	< 3,0 JOULES (E)		< 4,0 JOULES (E)		< 2,0 JOULES (E)	
Velocidad de disparo	hasta 145 m/s con BB 0,25 g		hasta 175 m/s con BB 0,25 g		hasta 125 m/s con BB 0,25 g	
Longitud del cañón	160 mm		202 mm		100 mm	
Longitud	295 mm		345 mm		250 mm	
Peso	930 g		990 g		945 g	
el Color	negro	cromo	negro	cromo	negro	cromo
Capacidad del cargador	8 BBs				6 BBs	
Distancia máx. de peligro	200 m					





 ATENCIÓN

- Manipule la pistola sólo cuando esté asegurada.
- Procure que la boca apunte siempre en una dirección segura.

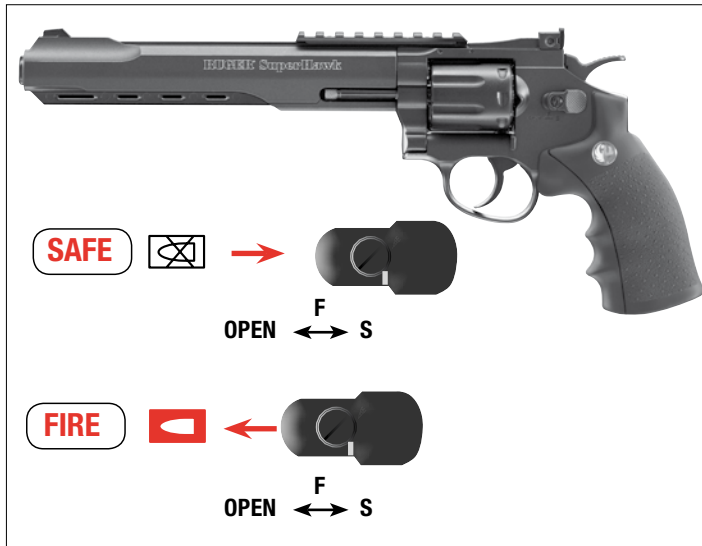

 ATENCIÓN

- Utilice únicamente cartuchos CO<sub>2</sub> de 12 g.
- Para guardar el arma extraiga los cartuchos de CO<sub>2</sub>.
- Al extraer el cartucho de CO<sub>2</sub>, es posible que se escape una pequeña cantidad de gas. Procure que sus manos no entren en contacto con el CO<sub>2</sub> en caso de fuga, ya que un eventual contacto con la piel puede causar congelación. No exponga el cartucho de CO<sub>2</sub> a un calor excesivo ni lo guarde a temperaturas superiores a los 54°C. Observe siempre las advertencias e instrucciones de seguridad del fabricante sobre la manipulación y el almacenamiento del cartucho de aire comprimido.

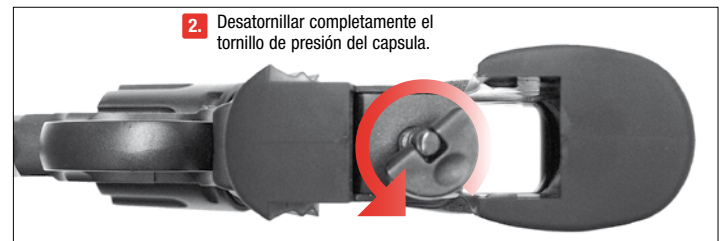



## COLOCAR / CAMBIAR LOS CARTUCHOS DE CO<sub>2</sub>



## LLENAR EL CARGADOR

ES

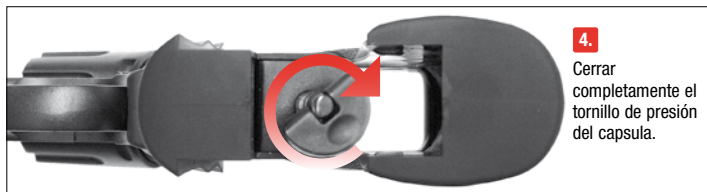

## ⚠ ATENCIÓN



Utilice únicamente bolas BB (que no presenten defectos) de calibre 6 mm. No utilice en ningún caso los siguientes tipos de bolas BB:

**1** Diámetro superior a los 6 mm, **2** Con cortes, **3** Con mitades que no coinciden, **4** Usadas o sucias. Si se utilizan proyectiles distintos de los apropiados, quedará anulada la garantía. Se recomienda el uso de bolas de precisión de la marca UMAREX/Walther. Para garantizar el buen funcionamiento del magazín, evite que la suciedad o el polvo entren en el mismo.



2.5680 / 2.5681 / 2.5780 / 2.5781

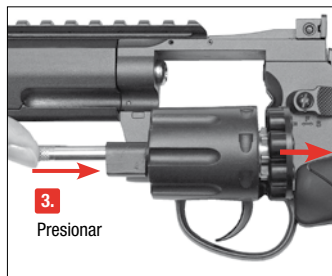

2.5778 / 2.5779





# LLENAR EL CARGADOR

**4.** 

2.5680 / 2.5681 / 2.5780 / 2.5781

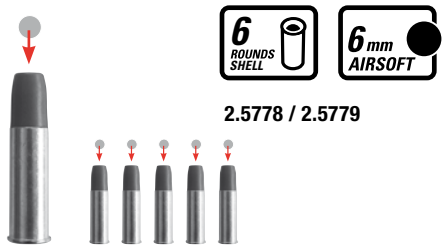

**4.** 

2.5778 / 2.5779

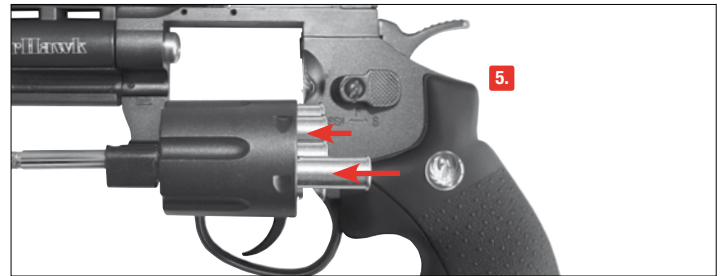

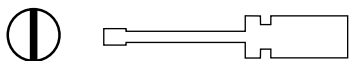

**Ajuste de altura**



**Ajuste lateral**

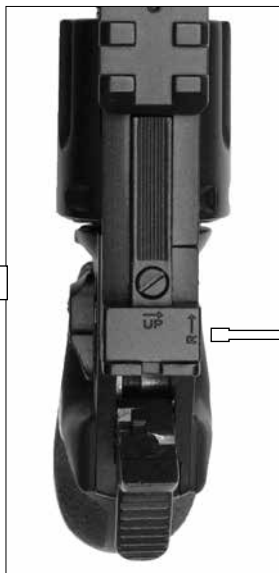
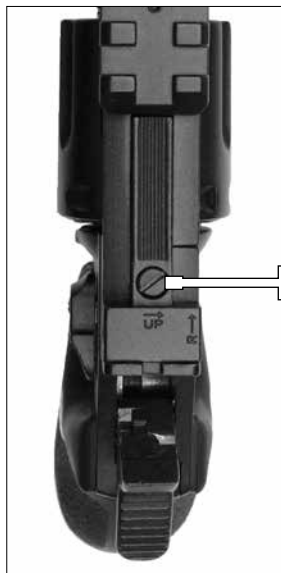

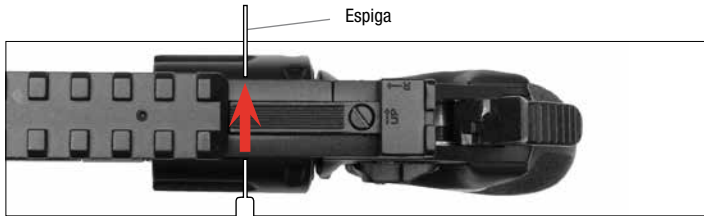

1. Sacar la espiga
2. Desatornillar el tornillo para ajustar la altitud
3. Quitar la mira
4. Apartar el rail Picatinny hacia atrás

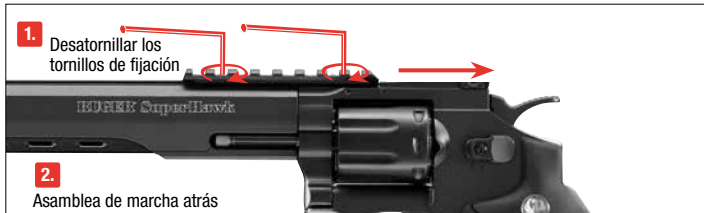
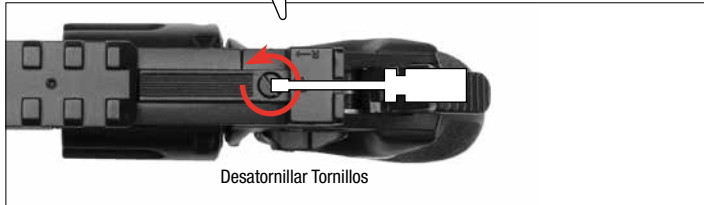
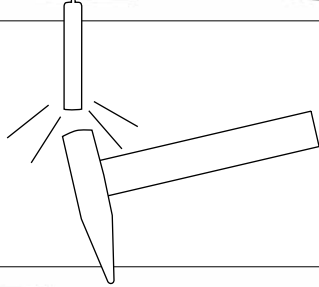

## ⚠️ ATENCIÓN

- Reajustar el „shoot up“ a „Normal“ antes limpiar el arma.
- No debe forzar la varilla de limpieza para introducirla dentro del cañón, porque podría dañar el arma.
- No vierta nunca aceite de silicona directamente dentro del cañón.

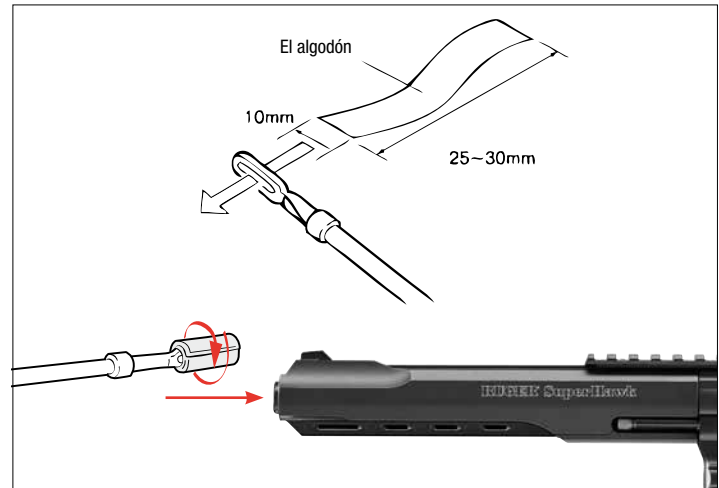

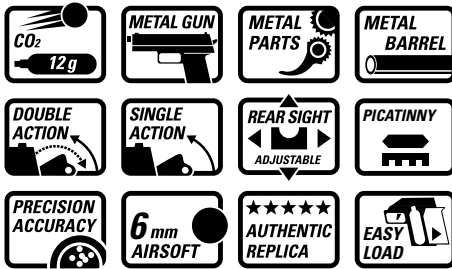

**SuperHawk** | 2.5680 - 8" / 2.5681 - 8"



**SuperHawk** | 2.5780 - 6" / 2.5781 - 6"



**SuperHawk** | 2.5778 - 4" / 2.5779 - 4"



**UMAREX®**

**UMAREX Sportwaffen GmbH + Co. KG**

Donnerfeld 2

59757 Arnsberg | Germany

Phone: +49 29 32 / 638-01

Fax: +49 29 32 / 638-222

verkauf@umarex.de | sales@umarex.de

www.umarex.com

We reserve the right to make color and design changes and technical improvements. No responsibility is accepted for printing errors or incorrect information.

Änderungen in Farbe und Design, sowie technische Verbesserungen, Druckfehler und Irrtum vorbehalten. Alle Angaben ohne Gewähr.

Sauf modifications de la couleur et du design ainsi que des améliorations techniques, erreurs d'impression et erreur. Toutes les données sont fournies sans garantie.

Salvo modificaciones de color y de diseño así como mejoramientos técnicos, erratas y error. Todos los datos sin garantía.

Con riserva di modifiche di colore e di design, di miglioramenti tecnici, di errori di stampa e di sbagli. Tutte le informazioni senza garanzia.

Изменения цвета и дизайна, а также технические улучшения, опечатки и ошибки не исключены. Мы не гарантируем точность сведений.

Zastrzegamy sobie prawo do pomyłek, błędów w druku, zmian koloru i designu, jak również do wprowadzania technicznych ulepszeń. Wszystkie informacje bez gwarancji.

© UMAREX Sportwaffen GmbH + Co. KG