

PRO TIPS

- ▶ Do not use oil or water.
 - ▶ Clean the Sharpening Guides and Benchstone after every sharpening with a dry brush.
 - ▶ You can sharpen freehand by removing the sharpening guides.
- Apply masking tape onto blade face to protect surface finish from abrasive grit scratches.
- ▶ Stop the tip of the knife on the abrasive to prevent rounding.

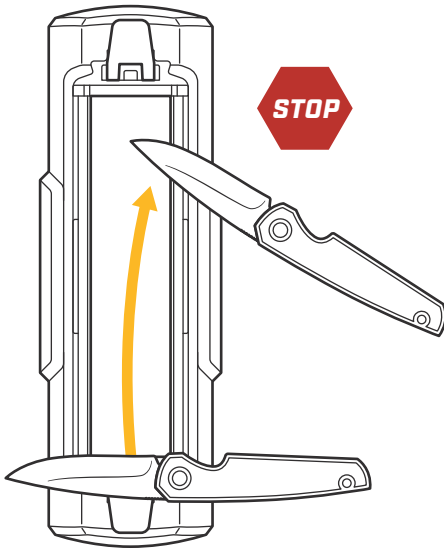

Work Sharp® is a registered trademark of Darex, LLC
For Patent Info Visit: worksharptools.com/patents
Designed, calibrated and quality checked in
Ashland, OR using foreign components.

QUESTIONS?

WorkSharpTools.com / 1.800.418.1439

PLEASE LEAVE A REVIEW WHERE
YOU PURCHASED YOUR PRODUCT



PP0004385 Rev. 0

INSTRUCTIONS

BENCHSTONE KNIFE SHARPENER

SET UP

- 1** Rotate Tri-Brasive™ Benchstone so the coarse diamond side is facing up.
- 2** Place the Tri-Brasive™ Benchstone into the base.
- 3** Install the Sharpening Guide to your desired edge angle.
 - ▶ 20° For Kitchen Knives
 - ▶ 25° For Outdoor Knives

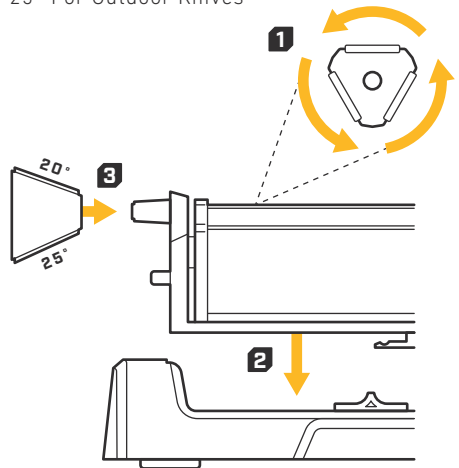

- 4** Unlock to allow the Tri-Brasive™ Benchstone to pivot, following the curve of the knife when sharpening.

Lock: For a rigid sharpening surface, lock the Pivot Response.

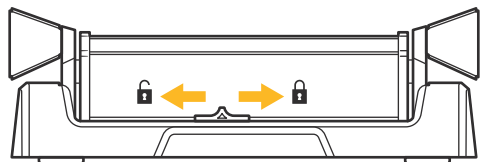

READY TO SHARPEN!

SHARPENING: WITH PIVOT RESPONSE (UNLOCKED)

1 Sharpen:

With coarse Tri-Brasive™ facing up, place knife flat on the sharpening guide at the heel of the blade. Keep knife handle perpendicular to the abrasive when sharpening. While maintaining the chosen angle, push the knife edge across the stone using light pressure all the way to the tip. Repeat until a burr is created along the entire length of the cutting edge. Once a burr is achieved, repeat this step using the opposing guide and pull the knife edge across the abrasive for the same number of strokes.

- ▶ You can also sharpen with the knife always moving away from you by switching hands. Use the method that feels most comfortable and safe for you.

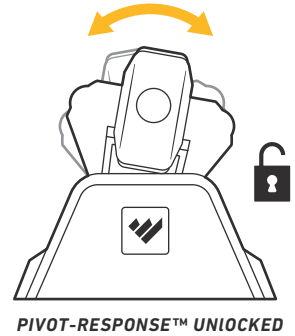
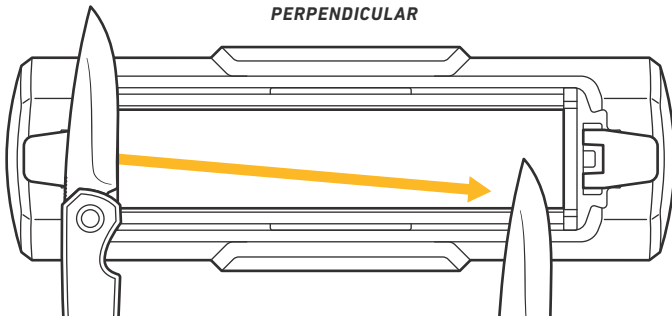

2 Refine:

Rotate Tri-Brasive™ Benchstone so the fine diamond is face up. Alternate 10-12 strokes until the edge is refined along the entire length of the cutting edge.

3 Hone:

Rotate Tri-Brasive™ Benchstone so the honing ceramic is face up. Repeat same method from step 2 using light pressure. Alternate until no burr remains.

SHARPENING: NO PIVOT RESPONSE (LOCKED)

1 When sharpening with the Pivot Response Locked, use a sweeping motion as you push the knife edge across the stone using light pressure and follow the curve of the blade all the way to the tip.

- ▶ All other steps to sharpen and hone are same as above.

