

ADDITIONAL PRO TIPS

- ▶ Use masking tape to protect high polish blade faces from abrasive grit scratches.
- ▶ You can sharpen freehand by removing the sharpening guides.

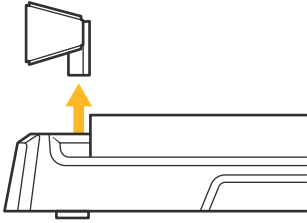

- ▶ Stop the tip of the knife on the abrasive to prevent rounding.

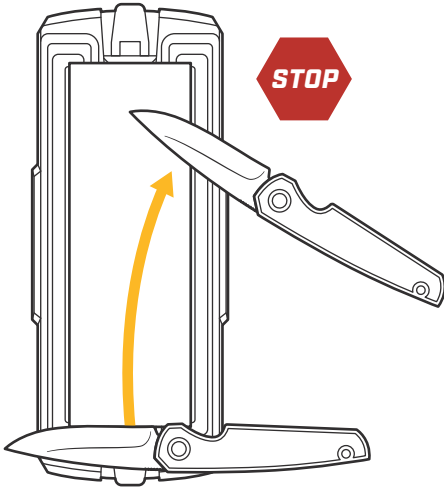

Work Sharp® is a registered trademark of Darex, LLC
For Patent Info Visit: worksharptools.com/patents
Designed, calibrated and quality checked in
Ashland, OR using foreign components.

QUESTIONS?

WorkSharpTools.com / 1.800.418.1439

PLEASE LEAVE A REVIEW WHERE
YOU PURCHASED YOUR PRODUCT



PP0004383 Rev. 0

INSTRUCTIONS

WHETSTONE KNIFE SHARPENER

SET UP

- 1 Fully submerge whetstone in water for 5-10 minutes or until it no longer releases air bubbles.
- 2 Place whetstone into base with Coarse (1000) side up for sharpening or Fine (6000) side up for edge refinement.
- 3 Install the Sharpening Guide to your desired edge angle:
 - ▶ 15° For Eastern Kitchen Knives
 - ▶ 17° For Kitchen Knives or Folding Knives

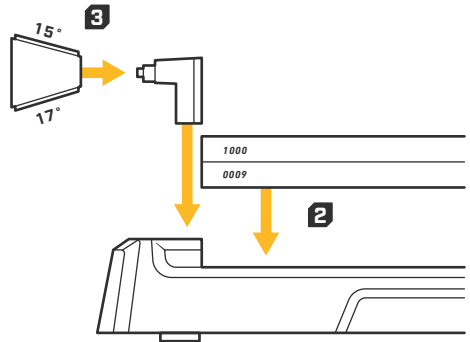

- 4 Keep a small cup of water and dry cloth within reach.

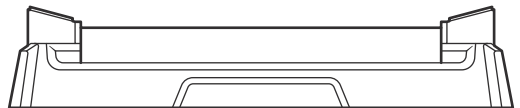

READY TO SHARPEN!

SHARPENING

1 Sharpen:

Install the whetstone with 1000 grit (coarse) side up. Keep stone wet while sharpening. Place knife flat on the sharpening guide at the heel of the blade. While maintaining the chosen angle, push the knife edge across the stone using light pressure and following the curve of the knife all the way to the tip. Repeat until a burr is created along the entire length of the cutting edge. Once a burr is achieved, repeat this step using the opposing guide and pull the knife edge across the abrasive for the same number of strokes.

- ▶ You can also sharpen with the knife always moving away from you by switching hands. Use the method that feels most comfortable and safe for you.

2 Honing or Re-Sharpen:

Flip over the whetstone so the 6000 grit (fine) side is face up. Rinse whetstone and water base surfaces with water to ensure there is no coarse grit / slurry on the stone. Repeat your preferred sharpening method from step one. Alternate final strokes using light pressure until the burr is removed along the entire length of the cutting edge.

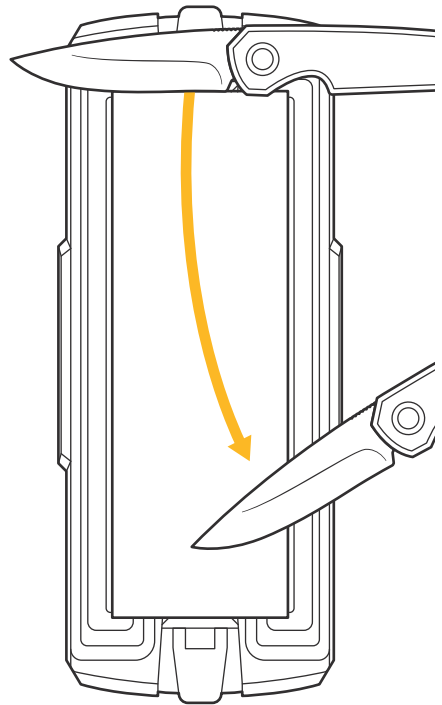
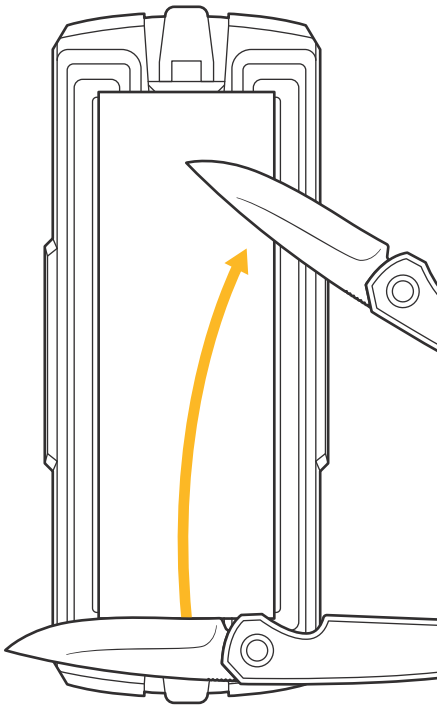

PRO TIPS

- ▶ Do not use oil and do not use dry. Water only.
- ▶ Use light pressure.
- ▶ Keep stone wet when sharpening to create a slurry for fastest and sharpest results.
- ▶ Use water to clean the stone surface when moving from the coarse to fine grit sides.
- ▶ Clean the whetstone, sharpening guides and water base after every sharpening.
- ▶ Store the sharpener clean and dry in between uses.